

Shanghai Mitsubishi Elevator Co., Ltd.
 Address: No. 811 Jiangchuan Road. Minhang, Shanghai, China
 Tel : +86-21-24083030/64303030
 Fax : +86-21-24083088
 Post: 200245

Overseas Business
 Tel : +86-21-24083525
 Fax : +86-21-24083514

 **上海三菱电梯有限公司**
 SHANGHAI MITSUBISHI ELEVATOR CO.,LTD.
www.smeccn.com

ISO ENERGY	
Manufacturer: Shanghai Mitsubishi Elevator Co., Ltd.	
Location: No. 887 Middle Huailu Road, Shanghai, P.R.China	
Type: K type	
Serial number: 13KSP30 194 8	
Low energy consumption	
A+++ < 50%	A+++
A++ < 55%	
A+ < 60%	
B < 65%	
C < 70%	
D < 75%	
E < 80%	
F > 85%	
High energy consumption	
Power consumption in the load condition	≤ 1,36 kW
Operation mode:	



Specifications subject to change without notice
 Printed in Dec. 2020

 **上海三菱电梯**
 SHANGHAI MITSUBISHI ELEVATOR

Smart K-II

Series K-II Escalators



Smart K-II

Product Advantages

Lead the Future with Intelligent Features	P.3
Safe and Reliable	P.5
A Wide Range of Optional Features	P.7
Comfortable and energy-Saving	P.8

Design

Decoration Options	P.9
Decorative Components	P.11
All LED Lighting System	P.15
Building interface protection device	P.17

Feature List	P.19
--------------------	------

Basic Specifications	P.21
----------------------------	------

Civil Work Drawing	P.23
--------------------------	------

Handrail Rated Width	P.24
----------------------------	------

Lead the Future with Intelligent Features

- ✓ Intelligent safety features: Monitor the conditions of passengers and the escalator which may pose possible hazards when an escalator is running, in a dynamic, real-time and active manner.
- ✓ Detect changes in the ambient volume, temperature, light level, and rainfall (outdoor) in real time to realize dynamic and intelligent control of escalators.
- ✓ Utilize real-time intelligent monitoring to improve the efficiency and pertinence of operations management and maintenance of escalators.

Safe and Reliable

- ✓ Over 20 standard safety features to fully ensure passenger safety.
- ✓ Proprietary anti-jump design of leaving steps and new step band double-guide to enable escalators to run more steadily and reliably.
- ✓ Standard user-friendly interface in Chinese and English and one-to-one detection of safety devices to improve the efficiency of escalator maintenance.

A Wide Range of Optional Features

- ✓ Greater rise and rich decoration options to perfect respond to high-end business scenarios.
- ✓ A wider range of speed, horizontal steps, balustrade height and radius of curvature of curved guide rails to select from to offer greater security.
- ✓ More types of inclinations to select from to meet different layout requirements.

Comfortable and Energy-saving

- ✓ LED lighting to save energy.
- ✓ Intelligent passenger sensors to prevent false startup caused by passing-by passengers and thus save energy.
- ✓ Optional bypass variable frequency and light-load energy-saving feature and phase-locking switch technology to enable escalators to run in a more energy-saving manner and provide a more comfortable ride experience.



Intelligent Product



Intelligent Escalator Terminal

- Identification and warnings of risky passenger behaviors (passengers ride with a pram):
Detect whether a passenger rides the escalator with a pram through the intelligent terminal at the landing areas of the escalator, and then give an acousto-optic alarm signal.
- Identification and warning of risky passenger behaviors (children play at the entrance):
Detect whether there are children playing at the landing areas of the escalator and give an acousto-optic alarm signal.
- Intelligent lubrication:
Automatically adjust the oiling strategy according to the rainfall level where an outdoor escalator is installed.
- Intelligent lighting control:
Automatically control the lighting according to the ambient illuminance and the operation state of the escalator.

Intelligent handrail sterilization (UV light)

Automatically sterilize the handrails by way of UV light based on the actual operation state of the escalator. Kill 99.99% of Staphylococcus Aureus and E. coli.

Intelligent lighting

Automatically select different heating strategies according to the ambient temperature and the operation state of the escalator.

Product Dimension	Function	Configuration
Intelligent Product	Identification and warning of risky passenger behaviors (passengers ride with a pram)	Optional package for intelligent terminal
	Identification and warning of risky passenger behaviors (children play at the landing areas)	
	Intelligent attentive announcer	
	Intelligent lighting control	
	Intelligent lubrication	
	Intelligent heating (if heaters are available)	Standard
	Intelligent handrail sterilization (UV light)	Optional
	Phase-locking switch of bypass inverter (VVVF escalators only)	Standard
	Light-load energy saving (VVVF escalators only)	Standard
	Passenger passing-by false-start prevention	Optional
	Control Panel LCD Operating Panel (CN/EN)	Standard
Multi-Functional Operating Panel (CN/EN)	Optional	
One-on-one Fault Detect (Safety Device)	Standard	



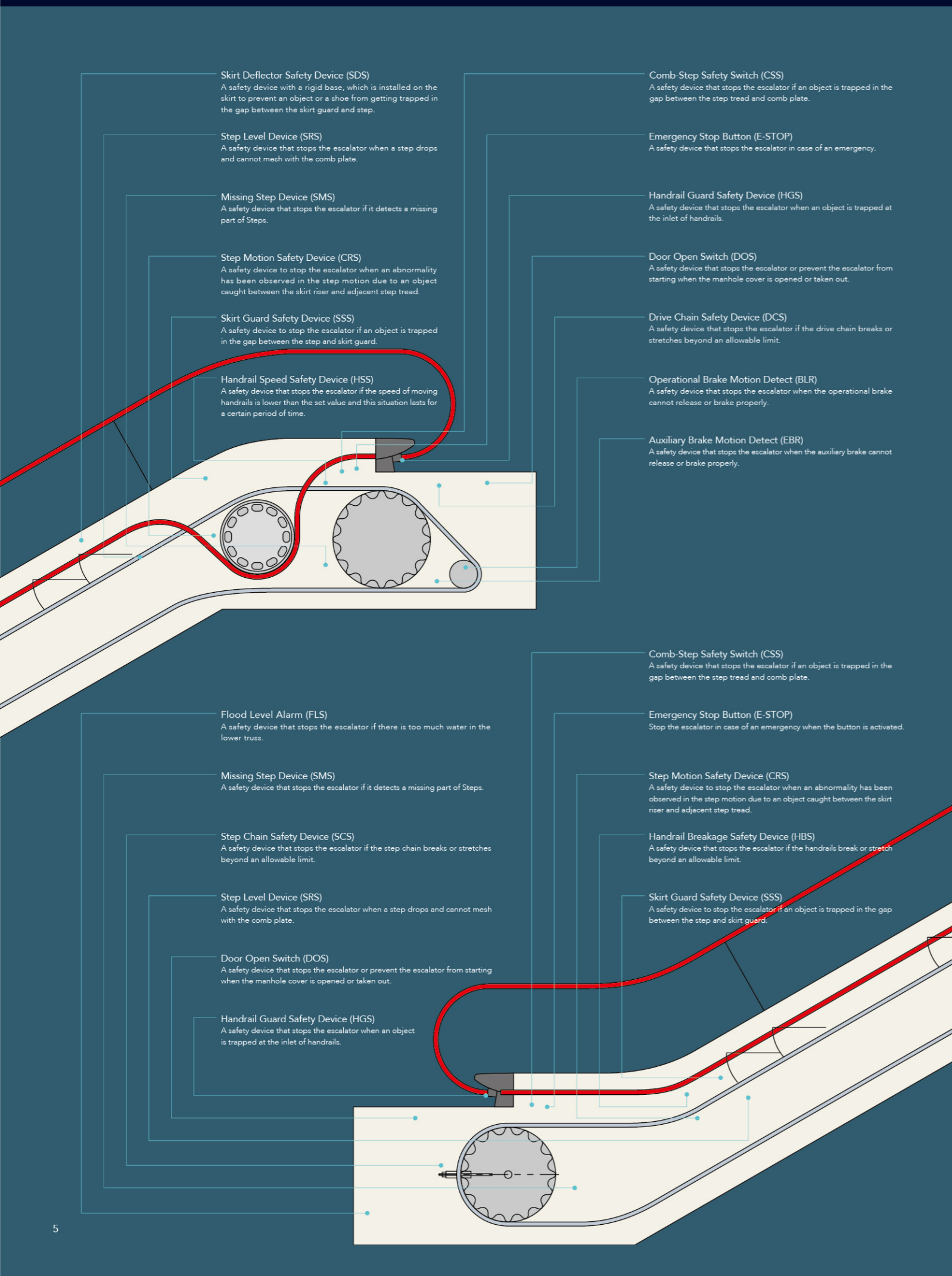

Quiet Turning and Meshing

The drive chain wheel is directly meshed with the step roller made of high polymer wearable resin, which avoids rigid shock between metal of the chain wheel and the step shaft.



Step Band Double-Guide

The entire travel of the leaving side of the step band adopts a double-guide structure, which makes the steps run more smoothly.



Leaving Step Anti-jump

Mitsubishi's proprietary step band guide rail structure which realizes anti-jumping of the leaving steps and thus provides better safety and reliability.



One-on-one Fault Detect (Safety Device)

Each safety device is one-to-one with fault codes, which speeds up troubleshooting and improves the efficiency of maintenance and repair.



Control Panel LCD Operating Panel

In the control panel, there is an LCD operating panel in Chinese and English, which is used to set parameters and check the escalator state, thus facilitating maintenance management.



Multi-Functional Operating Panel

An operating panel in Chinese and English can be installed at the landing areas of the escalator, which is used to set functions and check the faults, thus improving management efficiency.



Handrail Inlet Design

Continues Mitsubishi's hidden handrail inlet design, which greatly reduces the risk of objects getting trapped; a long and soft inlet guard is installed to provide multiple protection.



Skirt Deflector Safety Device

A safety device which prevents passengers stand too close to the edge of a step and prevent their feet from getting trapped in the gap between the skirt guard and step.

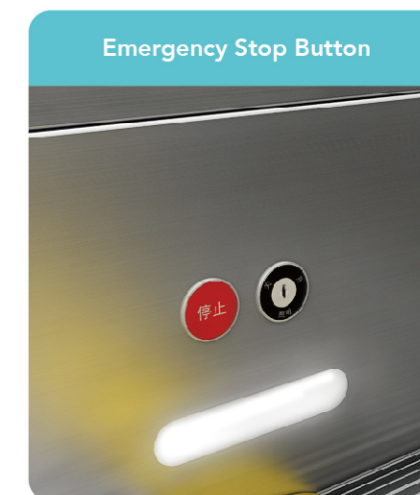

Emergency Stop Button

In case of an emergency, persons nearby or passengers can press the emergency stop button to stop the escalator manually.

- Balustrade height: 950/1000 mm
- Radius of curvature of curved guide rail: 2600/1500/1000 mm (upper); 2000/1000 mm (lower)
- Inclination: 27.3°, 30°, 35°
- Rise: 13 m
- Horizontal steps: 2/3/4 steps

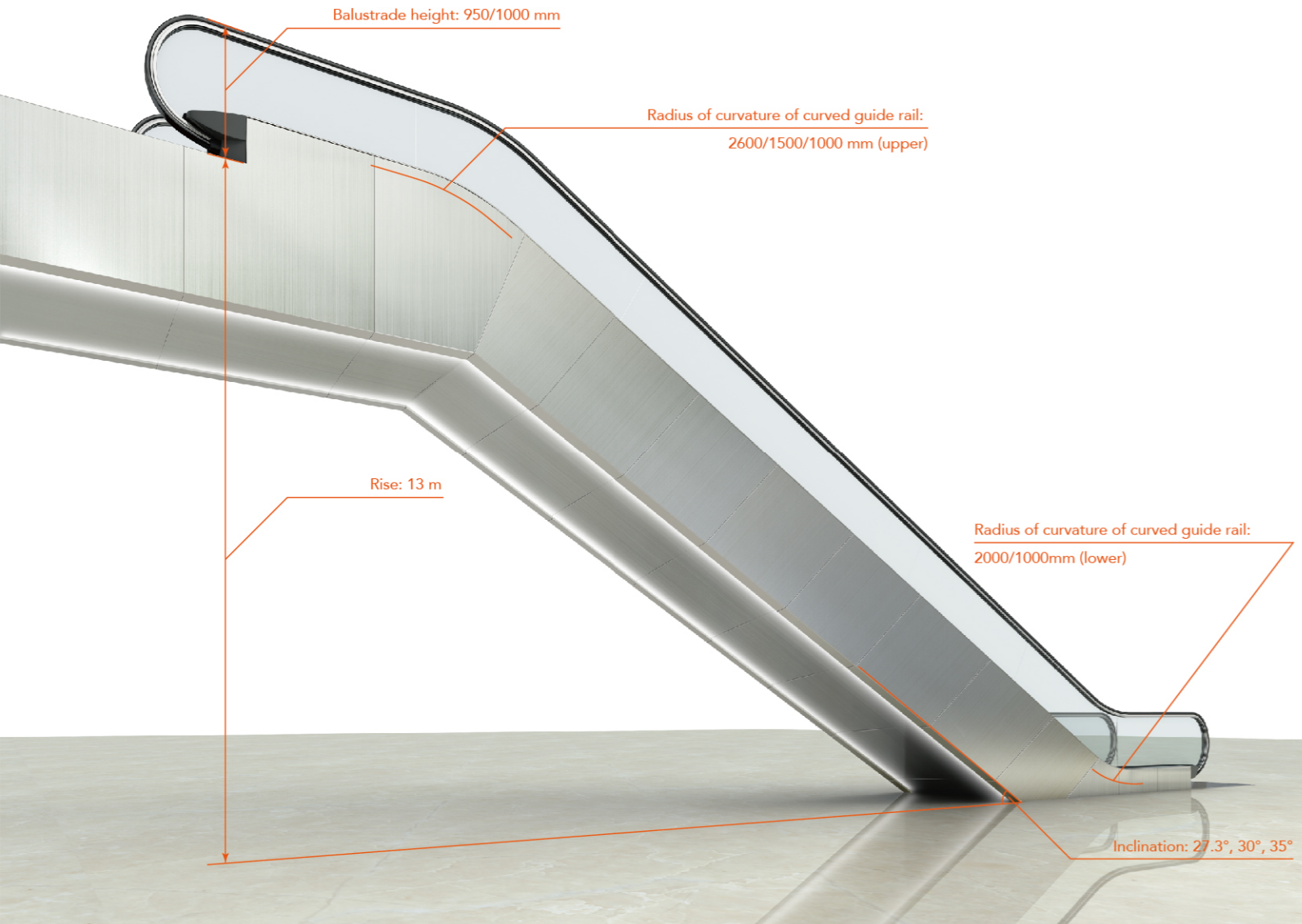

Bypass Inverter and Light-load Energy-saving Technology

At rated speed, automatically switch off the inverter and switch over to the working frequency grid to greatly extend the service life of the inverter. If the inverter has an unrecoverable fault, manually switch it to standby mode. If there is no passenger, automatically switch it to low speed or stop and standby mode; if under full load, feed back the regenerated energy to the grid to save energy.

Phase-locking Switch Technology

Mitsubishi's proprietary inverter is featured by modular design and small size; with sophisticated "active phase synchronization and phase-locking switch technology", it realizes smooth switch from variable frequency to working frequency and provides a more comfortable ride experience.

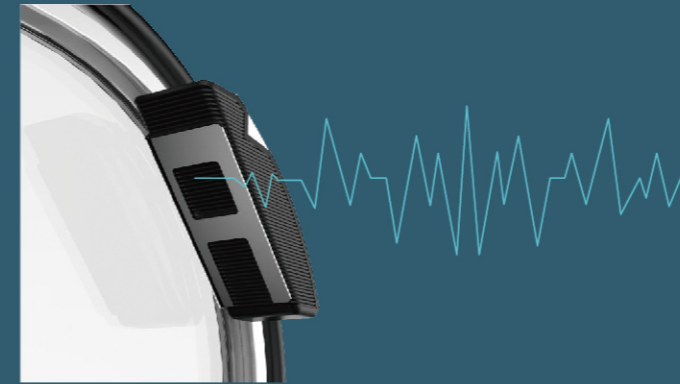

Intelligent Attentive Announcer

The voice announcer adaptive to ambient volume: In a noisy environment the volume of announcer increases and in a quiet environment the volume of announcer decreases, which ensures the overall comfort of the environment and passengers.



Intelligent Passenger Sensor

Intelligent sensors with innovative Time of Light technology can get an accurate picture of passenger's walking path by detecting the profile of the object to be detected, and effectively identify passengers who pass by and will not ride the escalator and those who will ride the escalators.

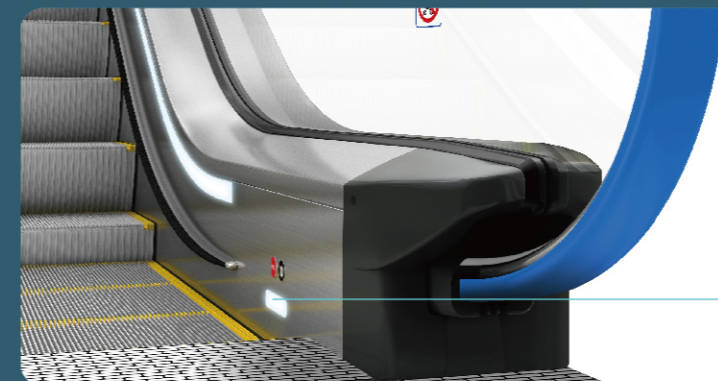

LED Lighting System

LED lighting improves the environmental quality and saves energy.

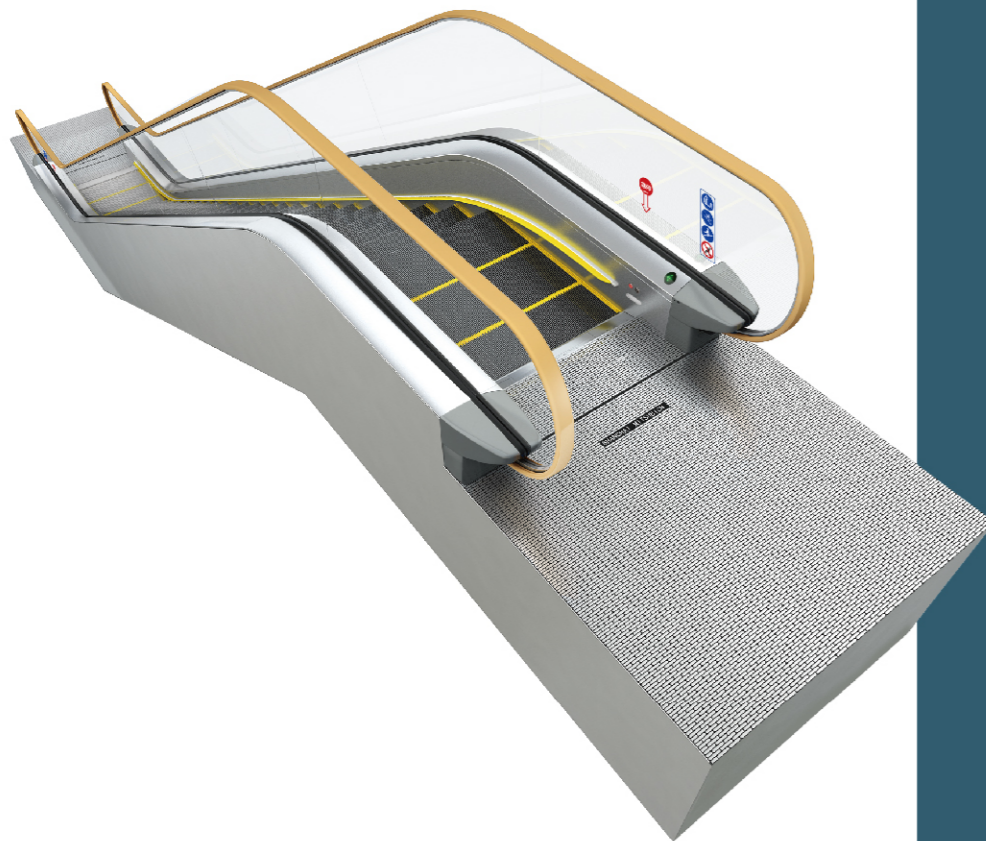

Balustrade KS-SB-II / KS-SBF-II

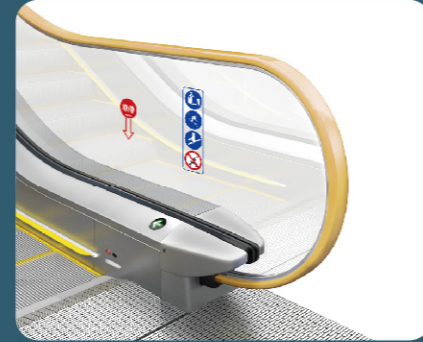

Part Description

Interior Panel

Fully transparent rectangular glass interior panel

Step

Aluminum alloy step with yellow resin strips at three sides (other specifications are available); silver gray coating

Handrail

Beige PU (NT-Beige) (other specifications are available)

Inner Deck and Outer Deck

Hairline-finish SUS

Handrail Inlet

ZHE-02A silver gray aluminum alloy (other specifications are available)

Operation Indicator

ZIN-02 (other models are available)

Skirt

Hairline-finish SUS (other specifications are available)

Floor Plate

ZCY-F02P SUS floor plate with anti-slip grooves (black coating inside)

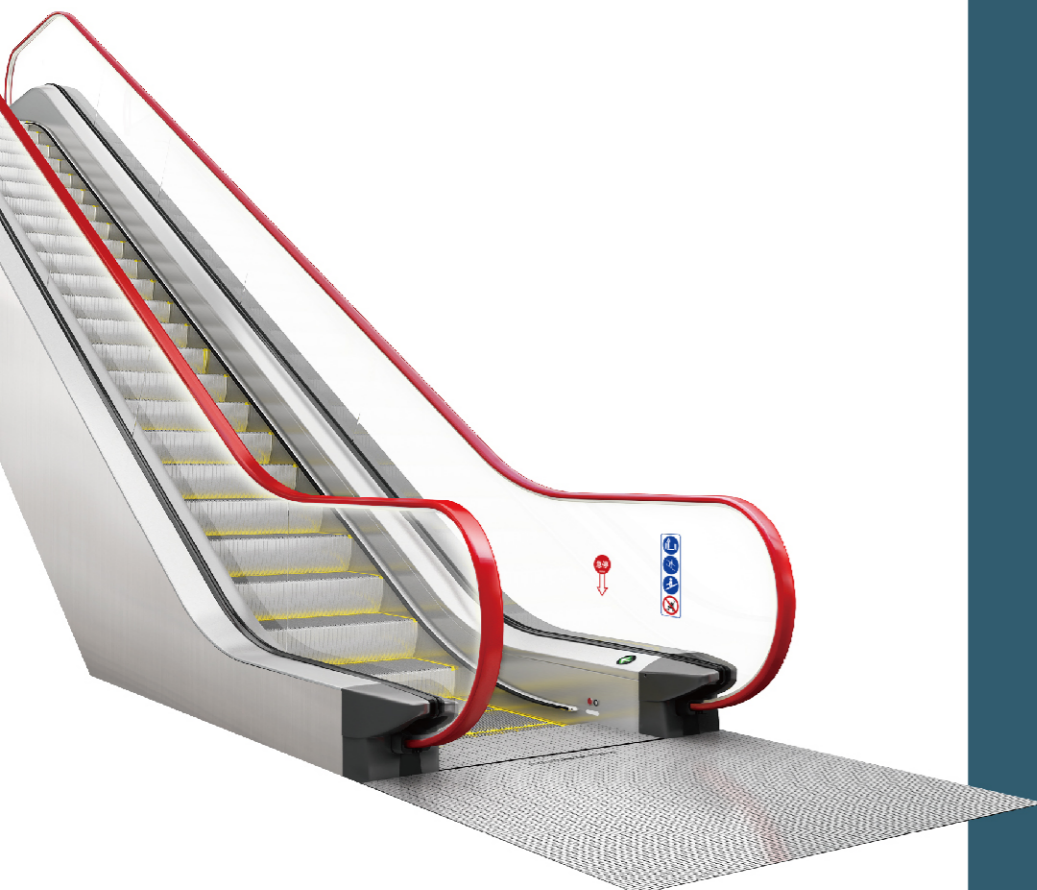

Balustrade KS-LB-II / KS-LBF-II

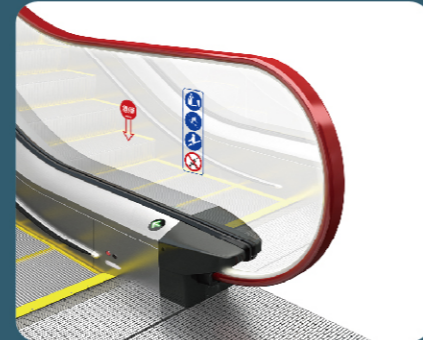

Part Description

Interior Panel

Fully transparent rectangular glass interior panel

Step

Aluminum alloy step with yellow resin strips at three sides (other specifications are available); silver gray coating

Handrail

Red PU (NT-Red) (other specifications are available)

Inner Deck and Outer Deck

Hairline-finish SUS

Handrail Inlet

ZHE-02A black gray aluminum alloy (other specifications are available)

Operation Indicator

ZIN-02 (other models are available)

Skirt

Hairline-finish SUS (other specifications are available)

Floor Plate

ZCY-F02P SUS floor plate with anti-slip grooves (black coating inside)

Handrail Lighting

Milky white LED lighting (other colors are available)



Balustrade KS-B-II / KS-BF-II

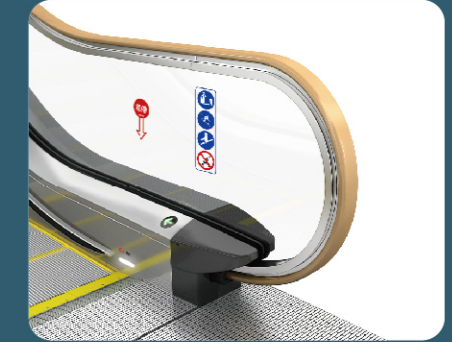

Part Description

Interior Panel

Fully transparent rectangular glass interior panel

Step

Aluminum alloy step with yellow resin strips at three sides (other specifications are available); silver gray coating

Handrail

Beige PU (NT-Beige) (other specifications are available)

Inner Deck and Outer Deck

Hairline-finish SUS

Handrail Inlet

ZHE-02A black gray aluminum alloy (other specifications are available)

Operation Indicator

ZIN-02 (other models are available)

Skirt

Hairline-finish SUS (other specifications are available)

Floor Plate

ZCY-F02P SUS floor plate with anti-slip grooves (black coating inside)

Balustrade KP-B-II / KP-BF-II

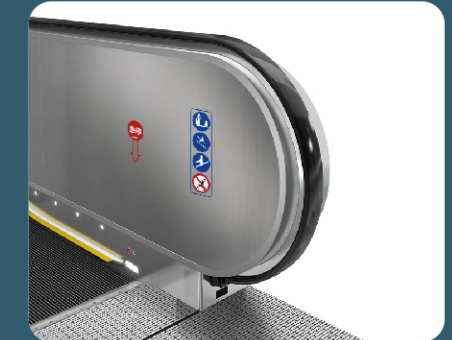

Part Description

Interior Panel

Hairline-finish rectangular SUS interior panel

Step

All aluminum alloy step (other specifications are available); black gray coating

Handrail

Black PU (NT-Black) (other specifications are available)

Main Deck

Hairline-finish SUS

Operation Indicator

At the newel balustrade

Skirt

Hairline-finish SUS (other specifications are available)

Floor Plate

ZCY-F02P SUS floor plate with anti-slip grooves (black coating inside) (other specifications are available)



Handrail



NT-Black
(Standard)



NT-Red
(Optional)



NT-Belge
(Optional)



NT-Blue
(Optional)



NT-Gray
(Optional)



NT-Charcoal
(Optional)



NT-Brown
(Optional)



NT-Green
(Optional)

Skirt

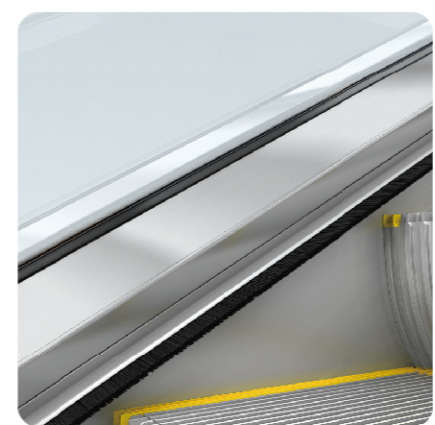

Hairline-finish SUS

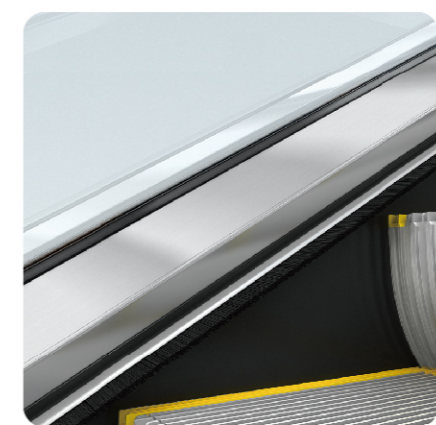

Fluoridized SUS (black)

Inner Deck and Outer Deck

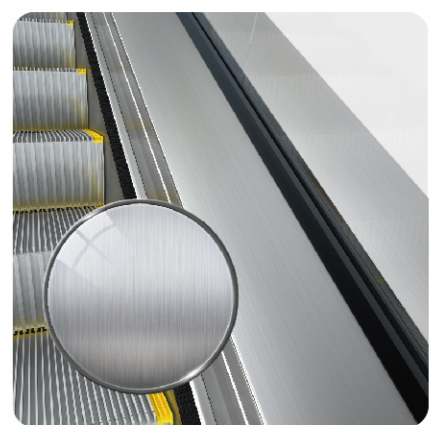

Hairline-finish SUS

Comb

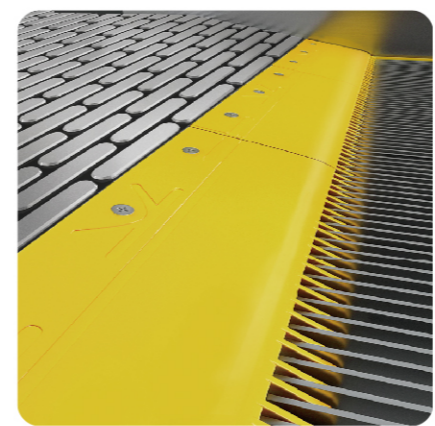

Yellow resin

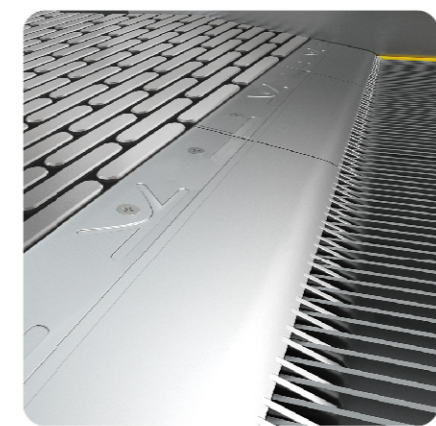

Silver aluminum alloy

Floor Number (optional)



Step



All aluminum alloy step
No yellow resin strips
Black gray coating

All aluminum alloy step
No yellow resin strips
Silver gray coating

Aluminum alloy step
Yellow resin strips at three sides
Black gray coating

Aluminum alloy step
Yellow resin strips at three sides
Silver gray coating

SUS step (only for indoor use)
Yellow resin strip at three sides
Black coating

Floor Plate

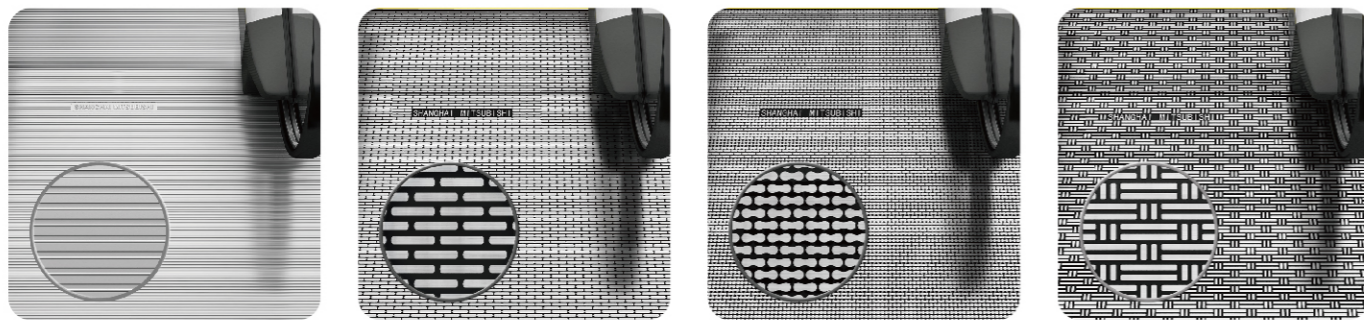

ZCY-F21P
Aluminum alloy floor plate
with anti-slip grooves

ZCY-F02P
Aluminum alloy floor plate
with anti-slip grooves
Dark coating inside

ZCY-F03P
Aluminum alloy floor plate
with anti-slip grooves
Dark coating inside

ZCY-F04P
Aluminum alloy floor plate
with anti-slip grooves
Dark coating inside

Operation Indicator

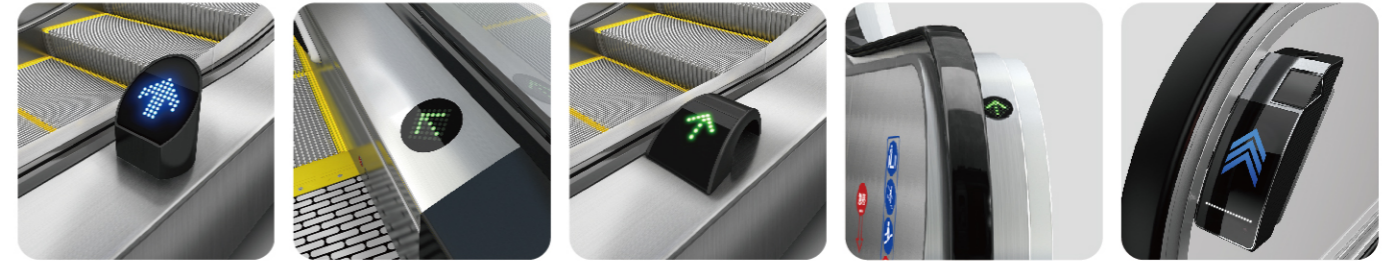

ZIN-03

ZIN-02

ZIN-01
Only for indoor use

**Newel balustrade
operation indicator**
Only for KP-B-II or KP-BF-II

**Intelligent terminal
operation indicator**
Applicable when intelligent
terminals are available

(inverter is of standard specifications in stop and standby mode, but optional for other modes)

Skirt Deflector Safety Device

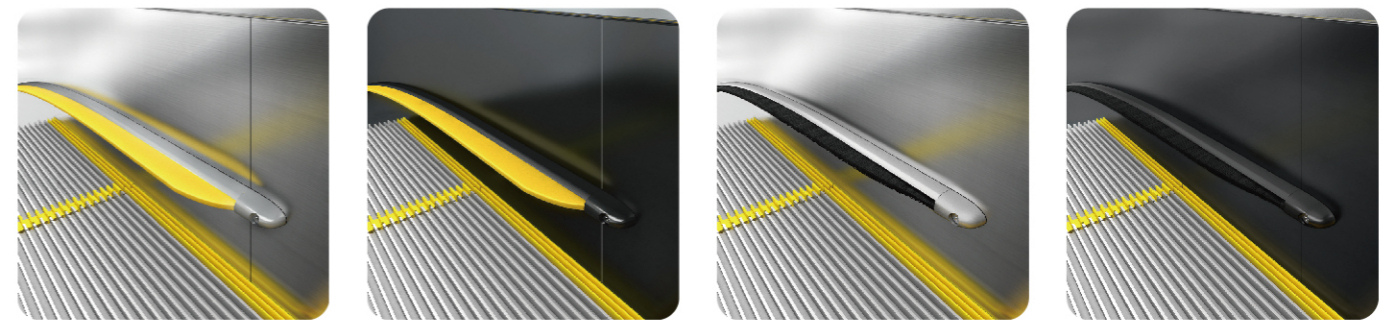

Silver base with yellow cleat

Black base with yellow cleat
(with black fluoridized stainless steel skirting plate)

Silver base with black brush

Black base with black brush
(with black fluoridized stainless steel skirting plate)

Handrail Inlet

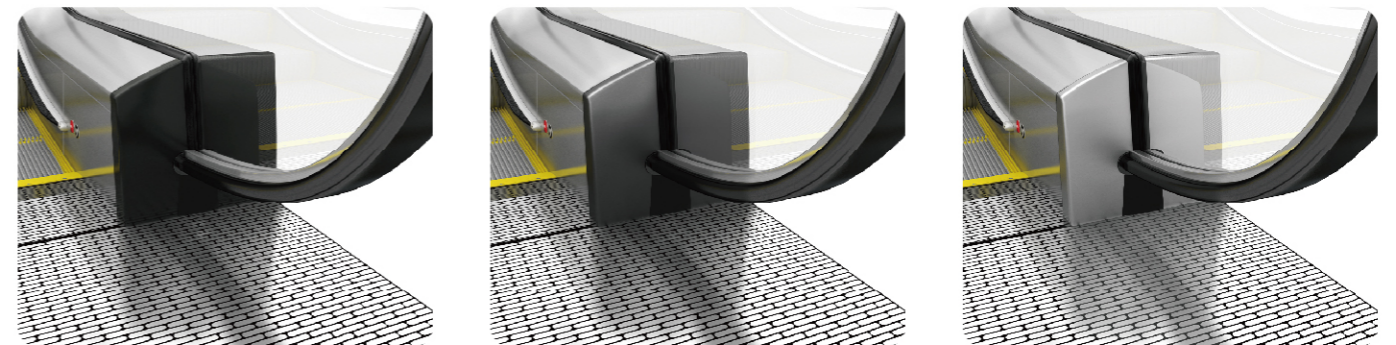

ZHE-01
Black gray resin square
Applicable to KS-SB-II/KS-SBF-II for indoor use

ZHE-01A
Black gray aluminum alloy square
Applicable to KS-SB-II/KS-SBF-II

ZHE-01A
Silver gray aluminum alloy square
Applicable to KS-SB-II/KS-SBF-II

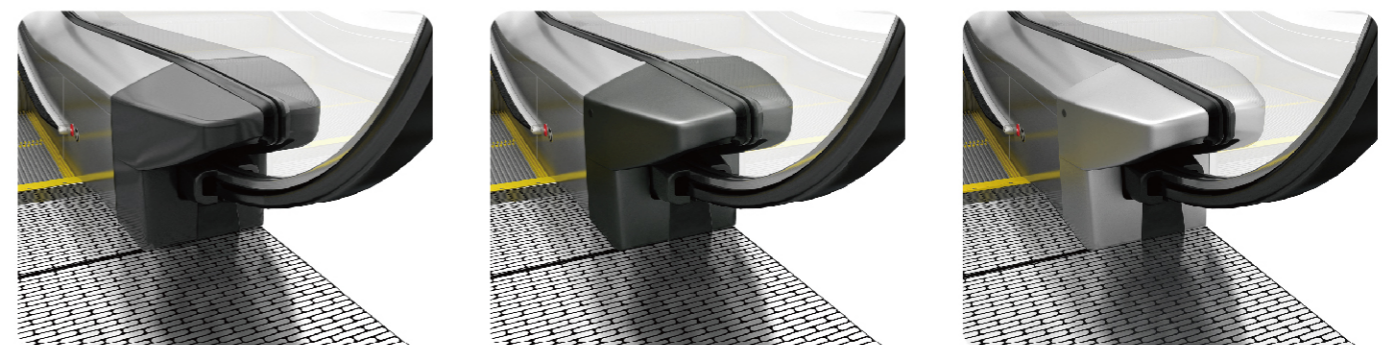

ZHE-02
Black gray resin streamlined
Applicable to KS-SB-II/KS-SBF-II/KS-B-II/KS-BF-II/KS-LB-II/KS-LBF-II

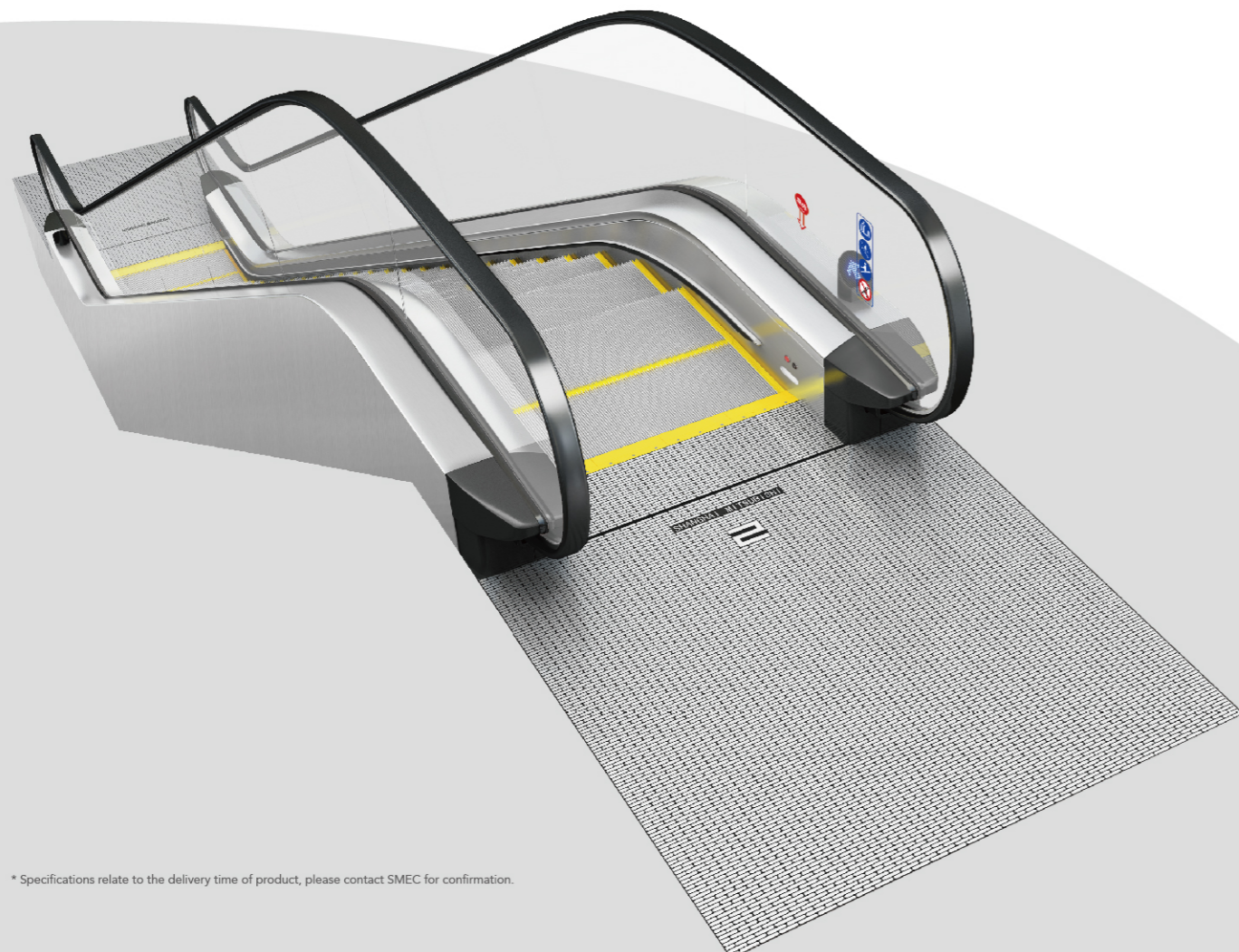

ZHE-02A
Black gray aluminum alloy streamlined
Applicable to KS-SB-II/KS-SBF-II/KS-B-II/KS-BF-II/KS-LB-II/KS-LBF-II

ZHE-02A
Silver gray aluminum alloy streamlined
Applicable to KS-SB-II/KS-SBF-II/KS-B-II/KS-BF-II/KS-LB-II/KS-LBF-II
Please contact SMEC for confirmation



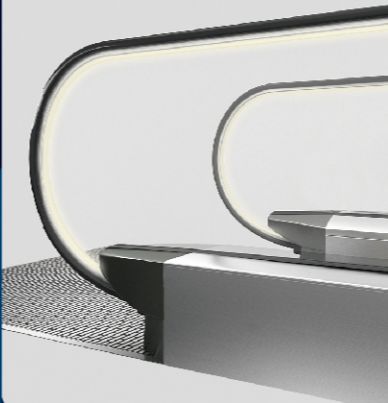

Smart K-II escalators use all LED lighting system, including handrail lighting, skirt lighting, comb lighting, and under-step lighting, to fully improve the environmental quality, save energy and ensure safety and reliability. Except that under-step lighting only uses green for warning purposes, various colors are available for other lighting systems.

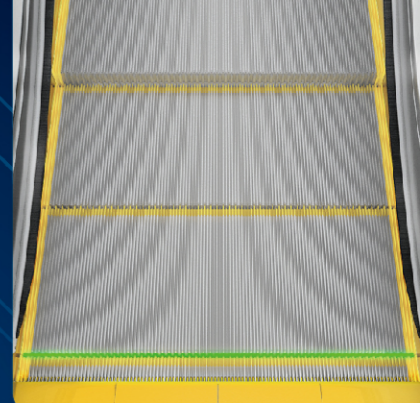
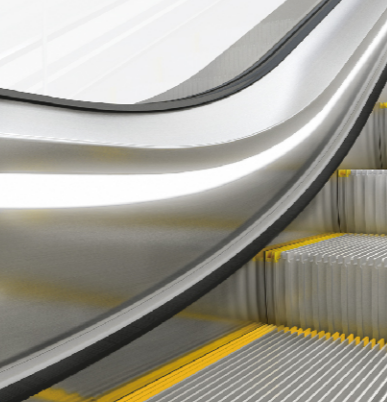
<p>Handrail Lighting</p>  <p>Colors can be selected applicable to KS-LB-II/KS-LBF-II only</p>	<p>Comb Lighting</p>  <p>Colors can be selected</p>	<p>Under-step Lighting</p>  <p>Green</p>
<p>Continuous Skirt Lighting</p>  <p>Colors can be selected</p>	<p>Dot-matrix Skirt Lighting</p>  <p>Colors can be selected</p>	

Note: The lighting system is optional.
Comb lighting/under-step lighting uses linkage control (which is switched on/off with the escalator); handrail lighting/skirt lighting uses manual control (which is switched on/off with the key switch of the escalator or manually through the multi-functional operating panel).

Optional Lighting Colors

Optional		Non-standard (contact SMEC)				
						
White	Light blue	Warm white	Blue	Green	Red	Orange



Anti-climb Device
(optional)

A safety device which prevents persons from getting onto and walking along the outer deck from a position near the ground outside of the escalator, or from trying to climbing onto and crossing over the balustrade and falling down from the escalator.



Outer Deck Block Device
(by owner)

A safety device which prevents persons, especially children, from getting into the outer deck from the upper and lower landing areas of the escalator, standing on the outer deck and walking along the deck.



Vertical Deflector
(by owner)

Vertical deflector is installed at the corner between the escalator and flooring and between criss-crossed escalators to prevent personal injury.

●: Standard, ○: Optional, —: N/A

Function	Description	Code	Non-variable frequency	Variable frequency
■ Control and Safety Features				
Phase Reversal and Open Phase Protection	Switch off the main circuit and control circuit to stop the escalator if phase reversal or open phase is detected in the input power supply.	3E	●	●
Anti-Reversal Protection	Switch off the power supply to the drive machine and brakes in case of accidental reversal.	ARP	●	●
Auxiliary Brake	An auxiliary brake stops the escalator before the speed exceeds 1.4 times of the rated speed, or if the traveling direction changes.	AUX-BK *1*2	●	●
Operational Brake Motion Detect	Stop the escalator when the operational brake cannot release or brake properly.	BLR	●	●
Operational Brake	The operational brake works to stop the escalator and keeps it at a standstill.	BRK	●	●
Step Motion Safety Device	Stop the escalator when an abnormality has been observed in the step motion due to an object caught between the skirt riser and adjacent step tread.	CRS	○	○
Comb-Step Safety Device	Stop the escalator if an object is trapped in the gap between the step tread and comb plate.	CSS	●	●
Contactormotion Detect	Stop the escalator when an abnormality has been observed in the contactor motion.	CTD	●	●
Drive Chain Safety Device	Stop the escalator if the drive chain breaks or stretches beyond an allowable limit.	DCS	●	●
Door Open Switch	Stop the escalator or prevent the escalator from starting when the manhole cover is opened or taken out.	DOS	●	●
Emergency Stop Button	Stop the escalator in case of an emergency when the button is activated.	E-STOP	●	●
Auxiliary Brake Motion Detect	Stop the escalator when the auxiliary brake cannot release or brake properly.	EBR *3	●	●
Electrical Safety Circuit Protection	Stop the escalator once the electrical safety devices in series work.	ESC	●	●
Braking Distance Monitoring	Prevent the escalator from restarting when the braking distance is more than 1.2 times of the maximum value.	ESD	●	●
Handrail Static Electricity Remover	Prevent handrails from generating static electricity.	HER	●	●
Overspeed Protection (1.2x)	Stop the escalator before the travel speed exceeds 1.2 times of the rated speed.	HGD1	●	●
Overspeed Protection (1.4x)	Stop the escalator before the travel speed exceeds 1.4 times of the rated speed.	HGD2 *3	●	●
Handrail Guard Safety Device	Stop the escalator when an object is trapped at the inlet of handrails.	HGS	●	●
Handrail Speed Safety Device	Stop the escalator if the speed of moving handrails is lower than the set value and this situation lasts for a certain period of time.	HSS	●	●
Low-Voltage Protection	Stop the escalator when the voltage of the inverter is too low.	LVP	—	●
Overcurrent Protection	Stop the escalator when the inverter has an overcurrent.	OCP	—	●
Motor Overload Protection	Stop the escalator when the motor is overloaded.	OCR	●	●
Overvoltage Protection	Stop the escalator when the voltage of the inverter is too high.	OVP	—	●
Power Phase Detect	Automatically monitor the phases and frequency of the power supply and bypass variable frequency to realize impact-free switch.	PLL	—	●
Passenger Sensor Fault	Diagnose the faults of passenger sensors and enable the escalator to cancel the standby mode in case of a fault.	PSD	—	○
Step Chain safety Device	Stop the escalator if the step chain breaks or stretches beyond an allowable limit.	SCS	●	●
Skirt Deflector Safety Device	A safety device with a rigid base, which is installed on the skirt to prevent an object or a foot from getting trapped in the gap between the skirt guard and step.	SDS	●	●
Step Static Electricity Remover	Prevent steps from generating static electricity.	SER	●	●
Missing Step Device	Stop the escalator if a missing part of Steps is detected.	SMS	●	●
Step Level Device	Stop the escalator when a step drops and cannot mesh with the comb plate.	SRS	●	●
Skirt Guard Safety Device	Stop the escalator if an object is trapped in the gap between the step and skirt guard.	SSS	○	○
Start Switch Bonding Detect	Prevent the escalator from restarting when the start switch is bonded.	SWD	●	●
Thermo-Detection in Inverter	Stop the escalator when the temperature of the inverter is too high.	THMF	—	●
Under Speed Protection	Stop the escalator when the travel speed of the escalator is lower than the set value.	USP	●	●
Flood Level Alarm	Stop the escalator if there is too much water in the lower truss.	FLS *4	●	●
Oil Level Alarm	Prevent the escalator from restarting when the level of the oiler is too low.	OILF *5	●	●
Over-Temperature Protection	Stop the escalator when over temperature of the motor is detected.	OTP	●	●
Handrail Breakage Safety Device	Stop the escalator if the handrails break or stretch beyond an allowable limit.	HBS	○	○
Operational Brake Wear Monitor	Prevent the escalator from restarting if the operational brake is found worn badly.		●	●

●: Standard, ○: Optional, —: N/A

Function	Description	Code	Non-variable frequency	Variable frequency
■ Emergency Operation Features				
Fireman's Service Stop	Stop the escalator when fireman's service signal is received.	FSS	○	○
■ Operational and Service Features				
Inspection Operation	Inspection Operation mode is convenient for installation and commissioning.	INSP	●	●
Light Shut Off - Manual	Turn on or off the lighting manually.	LO-M *7	●	●
Auto Operation	The escalator runs at rated speed when passengers are detected by passenger sensors, and switches over to standby mode when no passenger is detected.	MDA	—	●
Constant Speed Operation	The escalator always runs at rated speed.	MDC	●	—
Automatic oiling	Automatically oil the chains of the escalator at preset time.	OIL *5	●	●
Passenger Sensor -Through-beam Type	Passenger sensors are through-beam sensors.	PSB *8	—	○
Passenger Sensor -Microwave Non-column Type	Passenger sensors are microwave sensors. (The detection distance can be up to 1.5 m, but the feature of false start prevention is not available.)	PSM *8	—	○
Passenger Sensor-Column Type	Passenger sensors are photoelectric columns.	PSP *8	—	○
Passenger Sensor (EsPDS)	Passenger sensors are intelligent passenger sensors EsPDS (in standby mode, neglect passengers passing by to reduce false start).	EsPDS *8	—	○
Low-Speed Standby	The escalator travels at a speed lower than the rated speed under no load.	SBLS *9	—	○
Stop and Standby	The escalator stops under no load.	SBSP *9	—	○
Direct Start	The escalator is directly driven by the mains electricity during startup and operation.	SDT	●	—
Backup Start	The escalator can manually switch to be directly driven by the mains electricity if the inverter fails.	SBK	—	●
Travel Direction Alternative	The travel direction of the escalator can be selected.	UDA	●	●
Bypass Variable Frequency	The escalator is powered by an inverter during startup, stop and low-speed standby, and directly driven by mains electricity when it is running at rated speed.	VFBF	—	●
Heater	Monitor the temperature of the escalator through the temperature sensor in real time: When the temperature is lower than the set value, this device will prevent the escalator from starting and automatically start or turn off the heater according to the temperature.	HEAT *10	○	○
Intelligent handrail sterilization (UV light)	Automatically sterilize the handrails by way of UV light according to the actual operation state of the escalator.	IHS	○	○
Intelligent lighting control	Automatically control the lighting according to the ambient illuminance and the operation state of the escalator.	IIC *15	○	○
Intelligent heating	Select different heating strategies according to the ambient temperature and the operation state of the escalator.	IHC *11	●	●
Intelligent lubrication	Automatically adjust the oiling strategy according to the rainfall level where an outdoor escalator is installed.	ILC *15	○	○
Light-load energy saving	Under light load, decrease the input voltage of the motor to ensure the optimum current and thus reduce energy loss.	LLS	—	●
Identification and warning of risky passenger behaviors (passengers ride with a pram)	Detect whether a passenger rides the escalator with a pram through the intelligent terminal at the landing areas of the escalator, and then give an acousto-optic alarm signal.	WDB-BS *15	○	○
Identification and warning of risky passenger behaviors (children play at the landing areas of the escalator)	Detect whether there are children playing at the landing areas of the escalator and give an acousto-optic alarm signal.	WDB-PHE *15	○	○
■ Information and Display Features				
Safety Device Code Display	Detect the safety device one by one and display the error code accordingly.	ASD	●	●
BA interface	Output the signals of basic operation state of the escalator through passive dry contacts.	BA	○	○
Buzzer	Remind the passengers of the start, fault, reversal or other information of the escalator.	BUZ	●	●
Direction Indication	Remind passengers of the travel direction, out-of-service or no-entry or other information of the escalator.	DI *12	○	○
Fireman's Emergency Operation-Complete	A signal is sent when the fireman's emergency operation is completed.	FE-CP	○	○
Balustrade Lighting	Lighting at the lower ends of the balustrade.	L-BAL *13	●	●
Under-Step Lighting	Lighting at the position where the steps come in and out to show the edge of steps.	L-STP	○	○
Intelligent Escalator Monitoring System	Use computers to monitor the operation state of escalators and give start and stop instructions when necessary.	SMARTEYE	○	○
Skirt Lighting	Lighting on the skirt at both sides of the step band.	L-SKT *14	○	○

●: Standard; ○: Optional

Function	Description	Code	Non-variable frequency	Variable frequency
Information and Display Features				
Comb Lighting	Lighting on the comb plate at the position where the steps come in and out.	L-COMB *14	○	○
Door Open Alarm	The buzzer rings when the manhole cover is opened.	DOA	●	●
LED Lighting	Use LED for lighting source.	LED	○	○
Voice Announcer (CN)	The voice announcer informs passengers of safety tips in Chinese.	AAN-S01	○	○
Voice Announcer (CN/EN)	The voice announcer informs passengers of safety tips in Chinese and English.	AAN-S02	○	○
Voice Announcer (EN)	The voice announcer informs passengers of safety tips in English.	AAN-S03	○	○
Multi-functional Operating Panel	An operating panel installed at the landing areas of the escalator, which is used to operate the escalator, set parameters, check the operation state and error code, etc.	MFP	○	○
Control Panel LCD Operating Panel	In the control panel, there is an LCD operating panel, which is used to set parameters, check the operation state and error code, etc.	CPS-LCD	●	●
Intelligent Attentive Announcer	Automatically adjust the volume of announcer according to the changing ambient volume.	IAAN *15	○	○

Notes:

- *1 For commercial use escalators and those exceeding 6 m in rise; for airport use.
- *2 Optional for commercial use escalators and those not exceeding 6 m in rise.
- *3 When auxiliary brakes are provided.
- *4 Standard for outdoor or semi-outdoor escalators.
- *5 When auto oiler is provided.
- *6 Standard when worm gear reducer is provided.
- *7 When balustrade lighting or skirt lighting is available.
- *8 Select PSB, PSM, PSP or EsPDS (PSP is non-standard).
- *9 Select SBLs or SBSP.
- *10 Optional for outdoor escalators; standard when ambient temperature is below 0°C.
- *11 Standard when heaters are provided.
- *12 Non-standard for non-variable frequency escalator.
- *13 Standard for KS-LB-II and KS-LBF-II.
- *14 Non-standard for outdoor escalators.
- *15 Intelligent terminals are required.

Item	Content			Description
Between Moving Handrails	1200	1000	800	
Between Skirt Guards	1000	800	600	
Models	KS-SB-II/KS-SBF-II			Transparent tempered glass panel, no under-handrail lighting, slim handrails, max. rise 10 m
	KS-B-II/KS-BF-II			Transparent tempered glass panel, no under-handrail lighting, common handrails, max. rise 13 m
	KS-LB-II/KS-LBF-II	Slim		Transparent tempered glass panel, under-handrail lighting; slim handrails Non-standard confirmation required for semi-outdoor and outdoor use, max. rise 10 m
		Common		Transparent tempered glass panel; under-handrail lighting; common handrails Non-standard confirmation required for semi-outdoor and outdoor use; max. rise 13 m
	KP-B-II/KP-BF-II			Hairline-finish stainless panel; no under-handrail lighting, max. rise 13 m
Application	Commercial use			
	Airport			Applicable to airports with fewer passenger flow, non-standard confirmation required for special load requirements
Environment	Indoor			
	Outdoor, semi-outdoor			A roof must be provided
Drive System	Direct drive system			
	AC VVVF drive system			Optional
Power Supply	380V 50Hz 3-phase, 5-wire			Non-standard confirmation is required for other power supply specifications and frequency
Light Power Supply	220V 50Hz single-phase			Non-standard confirmation is required for other power supply specifications and frequency
Handrail Height	950mm			Standard
	1000mm			Optional
Inclination	30°			
	35°			Only for commercial use
	27.3°			
Rise	1400 mm – 13000 mm			Inclination 30°
	1606 mm – 6000 mm			Inclination 35°
	1285 mm – 13000 mm			Inclination 27.3°
Rated Speed	0.4m/s			Optional for commercial use of inclination 30° and 27.3°, max. rise 10 m
	0.5m/s			Standard, max. rise 13 m
	0.65m/s			Optional for inclination 30° and 27.3°, max. rise 10 m
Horizontal Movement	800mm			2 horizontal steps
				Standard for commercial use and rise not exceeding 6 m; optional for rated speed 0.4 m/s and 0.5 m/s only
	1200mm			3 horizontal steps
				Standard for commercial use and rise not exceeding 6 m; standard for rise exceeding 6 m and commercial use
1600mm			4 horizontal steps	
			Optional for commercial use and inclination 30° and 27.3°; optional for airport	
Radius of Curvature of Curved Guide Rail (Upper/Lower)	1000mm/1000mm			
	1500mm/1000mm			
	2600mm/2000mm			

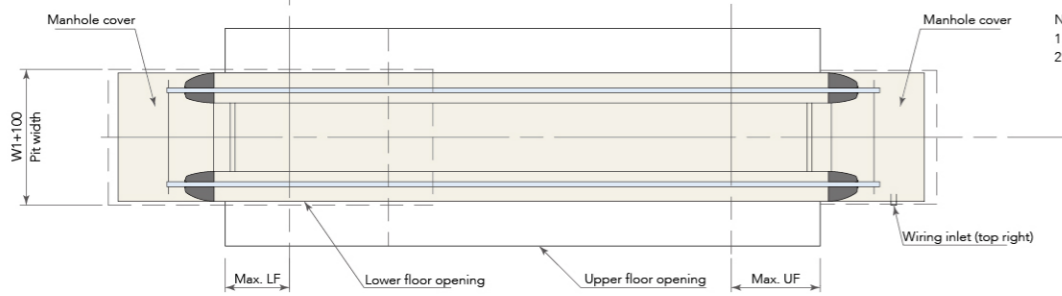
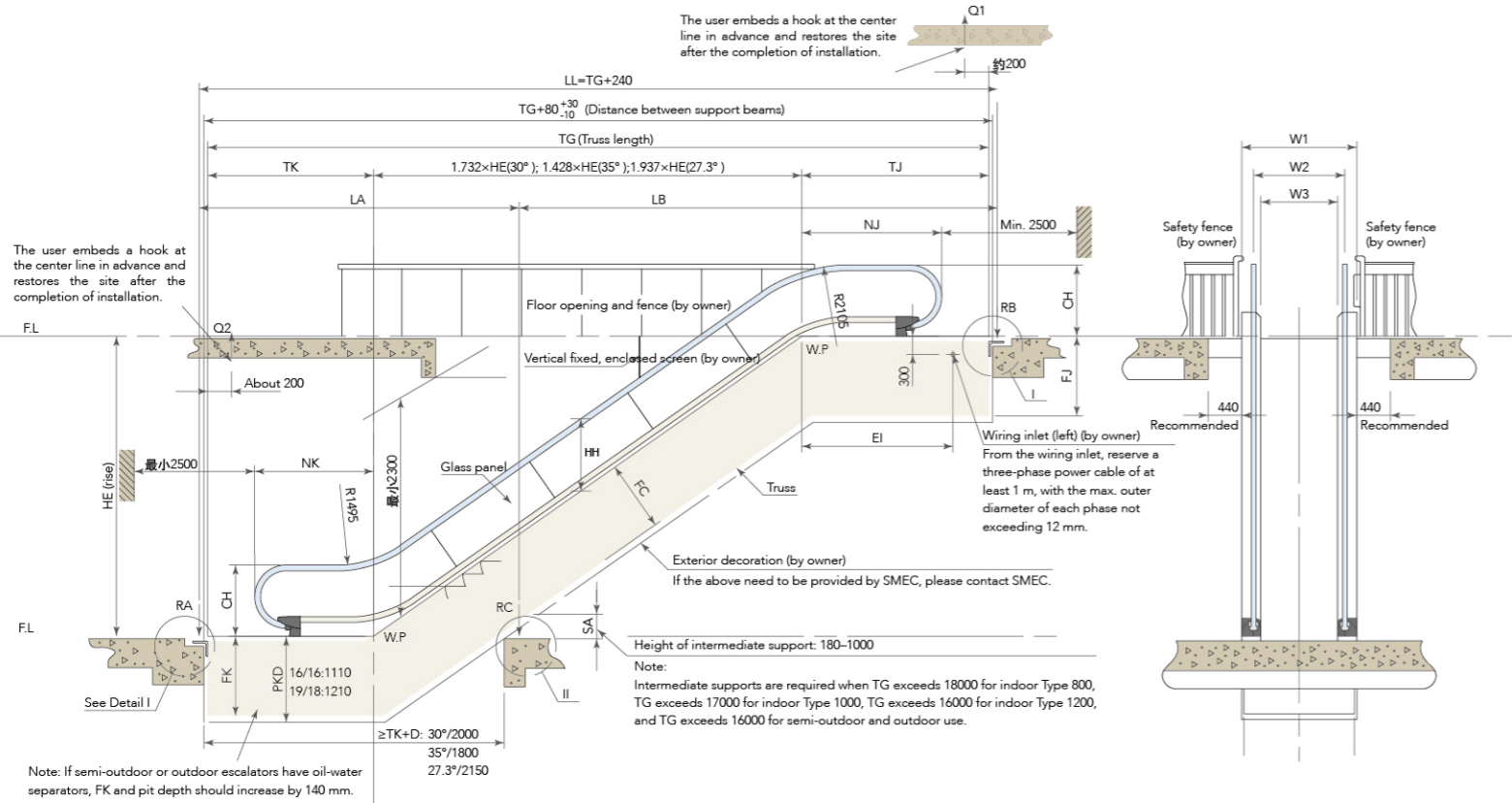

Detail I of end support drawing

Detail II of intermediate support beam

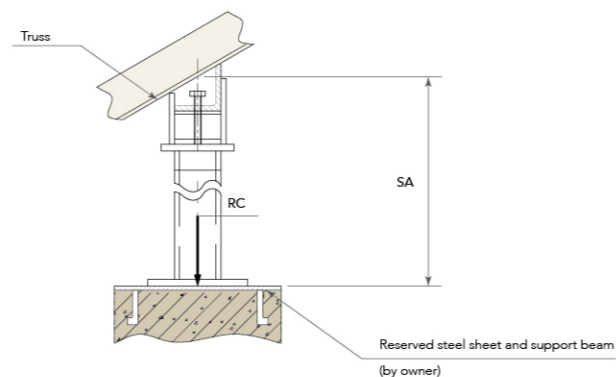
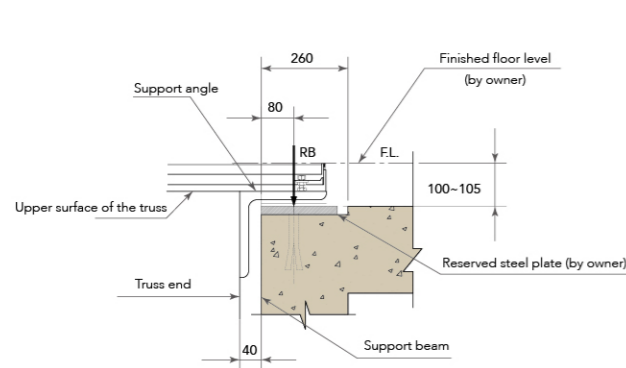

Item(mm)	Inclination	Between Moving Handrails	Horizontal Steps	Reducer Specification	Radius of curvature of curved guide rail (upper/lower)(mm)	Comb teeth of top /bottom step sprocket	Standard	Optional	
Upper Truss Length (TJ)	30°	1200	2	E611101	1000/1000	16/16	2435	2436-3535	
					1500/1000	16/16	2550	2551-3650	
					1500/1000	19/18	2625	2626-3725	
				2600/2000	19/18	2885	2886-3985		
				FTS180.1	1000/1000	16/16	2735	2736-3835	
					1500/1000	16/16	2850	2851-3950	
			1500/1000		19/18	2925	2926-4025		
			1000	E611101	3	1000/1000	16/16	2840	2841-3940
						1500/1000	16/16	2955	2956-4055
						2600/2000	19/18	3290	3291-4390
				J611102A000	FTS180.1	1000/1000	16/16	3140	3141-4240
						1500/1000	16/16	3255	3256-4355
		1500/1000				19/18	3330	3331-4430	
		800	E611101	4	2600/2000	19/18	3590	3591-4690	
					1500/1000	19/18	3435	3436-4535	
					2600/2000	19/18	3695	3696-4795	
			J611102A000	FTS180.1	1500/1000	19/18	3735	3736-4835	
					2600/2000	19/18	3995	3996-5095	
					1000/1000	16/16	2935	2936-3535	
		35°	1200	E611101	2	1500/1000	16/16	3050	3051-3650
						1500/1000	19/18	3125	3126-3725
						2600/2000	19/18	3385	3386-3985
				FTS180.1	1000/1000	16/16	3235	3236-3835	
					1500/1000	16/16	3350	3351-3950	
	1500/1000				19/18	3425	3426-4025		
	1000		E611101	3	2600/2000	19/18	3685	3686-4285	
					1000/1000	16/16	3340	3341-3940	
					1500/1000	16/16	3455	3456-4055	
			FTS180.1	1500/1000	19/18	3530	3531-4130		
				1000/1000	16/16	3640	3641-4240		
				1500/1000	16/16	3755	3756-4355		
	800	E611101	4	1500/1000	19/18	3830	3831-4430		
				2600/2000	19/18	4090	4091-4690		
				1500/1000	19/18	3935	3936-4535		
		FTS180.1	2600/2000	19/18	4195	4196-4795			
			1500/1000	19/18	4235	4236-4835			
			2600/2000	19/18	4495	4496-5095			
	27.3°	1200	E611101	2	1000/1000	16/16	2495	2496-3595	
					1000/1000	16/16	2795	2796-3895	
					1000/1000	16/16	2900	2901-4000	
		FTS180.1	1000/1000	16/16	3200	3201-4300			
			1000/1000	16/16	2995	2996-3595			
			1000/1000	16/16	3295	3296-3895			
	1000	E611101	3	1000/1000	16/16	3400	3401-4000		
				1000/1000	16/16	3700	3701-4300		
				1000/1000	16/16	2501	2502-3601		
		FTS180.1	1500/1000	19/18	2576	2577-3676			
			1500/1000	19/18	2810	2811-3910			
1500/1000			16/16	2801	2802-3901				
FTS180.1	1500/1000	19/18	2876	2877-3976					
	2600/2000	19/18	3110	3111-4210					

Item(mm)	Inclination	Between Moving Handrails	Horizontal Steps	Reducer Specification	Radius of curvature of curved guide rail (upper/lower)(mm)	Comb teeth of top /bottom step sprocket	Standard	Optional		
Upper Truss Length (TJ)	27.3°	1200 1000	3	E611101	1500/1000	16/16	2960	2907-4006		
					1500/1000	19/18	2981	2982-4081		
					2600/2000	19/18	3215	3216-4315		
				J611102A000 FTS180.1	1500/1000	16/16	3206	3207-4306		
					1500/1000	19/18	3281	3282-4381		
					2600/2000	19/18	3515	3516-4615		
			2600/2000	19/18	3620	3621-4720				
			J611102A000 FTS180.1	1500/1000	19/18	3686	3687-4786			
			2600/2000	19/18	3920	3921-5020				
			1500/1000	19/18	3076	3077-3676				
			2600/2000	19/18	3310	3311-3910				
			FTS180.1	1500/1000	16/16	3301	3302-3901			
		1500/1000		19/18	3376	3377-3976				
		2600/2000		19/18	3610	3611-4210				
		1500/1000	19/18	3481	3482-4081					
		2600/2000	19/18	3715	3716-4315					
		FTS180.1	1500/1000	16/16	3706	3707-4306				
			1500/1000	19/18	3781	3782-4381				
			2600/2000	19/18	4015	4016-4615				
		2600/2000	19/18	4120	4121-4720					
		FTS180.1	1500/1000	19/18	4186	4187-4786				
		2600/2000	19/18	4420	4421-5020					
		Lower Truss Length (TK)	30°	/	2	/	1000/1000	16/16	2178	2179-3278
							1500/1000	16/16	2178	2179-3278
1500/1000	19/18						2253	2254-3353		
2600/2000	19/18						2484	2485-3584		
1500/1000	16/16				2583	2584-3683				
1500/1000	19/18				2658	2659-3758				
2600/2000	19/18				2889	2890-3989				
2600/2000	19/18				3294	3295-4394				
35°	/				2	/	1000/1000	16/16	2213	2214-3313
							1000/1000	16/16	2618	2619-3718
					1500/1000	19/18	2236	2237-3336		
					27.3°	/	2	/	2600/2000	19/18
		1500/1000	16/16	2566					2567-3666	
		1500/1000	19/18	2641					2642-3741	
		2600/2000	19/18	2847					2848-3947	
		2600/2000	19/18	3252			3253-4352			
		Upper Truss Depth (FJ)	/	/			/	E611101 J611102A000 FTS180.1	1000/1000	16/16
					1500/1000	16/16			1060	/
					1500/1000	19/18			1270	/
					2600/2000	19/18			1270	/
Upper Truss Depth (FK)	/	/	/	/	/	16/16	1020	/		
					/	19/18	1120	/		

Note: When oil-water separators are available, FK should be increased by 140 mm.

Item(mm)	Inclination	Between Moving Handrails	Horizontal Steps	Rise	Radius of curvature of curved guide rail (upper/lower)(mm)	Comb teeth of top /bottom step sprocket	Standard	Optional				
Middle Truss Depth(FC)	30	/	/	/	/	/	918	/				
	35	/	/	/	/	/	938	/				
	27.3	/	/	/	/	/	906	/				
Horizontal Handrail Height (CH)	30	/	/	/	/	/	950	1000				
	35	/	/	/	/	/	950	1000				
	27.3	/	/	/	/	/	950	1000				
Inclined Handrail Height (HH)	30	/	/	/	/	/	935	1005				
	35	/	/	/	/	/	989	1062				
	27.3	/	/	/	/	/	979	1013				
Upper Balustrade Length (NJ)	30°	/	2	/	1000/1000	/	1759	1784				
					1500/1000	/	1874	1899				
					2600/2000	/	2134	2159				
					1500/1000	/	2279	2304				
					2600/2000	/	2539	2564				
					2600/2000	/	2944	2969				
			35°	/	2	/	1000/1000	/	1819	1844		
							1000/1000	/	2224	2249		
					2600/2000	/	2059	2084				
					2600/2000	/	2464	2489				
					4	/	1500/1000	/	2635	2660		
							2600/2000	/	2869	2894		
	Lower Balustrade Length (NK)	30°			/	2	/	1000/1000	/	1502	1527	
								1500/1000	/	1502	1527	
								2600/2000	/	1733	1758	
								1500/1000	/	1907	1932	
								2600/2000	/	2138	2163	
								2600/2000	/	2543	2568	
			35°	/		2	/	1000/1000	/	1537	1562	
								1000/1000	/	1942	1967	
						2600/2000	/	1691	1716			
						2600/2000	/	2096	2121			
						4	/	1500/1000	/	2295	2320	
								2600/2000	/	2501	2526	
Escalator Width (W1)	/	1200 1000 800 1200 1000 800			/	/	/	/	/	≤10m		
										1491	/	
										1293	/	
										1095	/	
										1541	/	
										1343	/	
>10m	/	/	/	/	/	/	/	1145	/			
								Inclination	Environment	LA(mm)	LB(mm)	LC(mm)
								30°	Indoor	(TK+459)~16000	(TJ+1013)~16000	500~16000
									Semi-outdoor/Outdoor	(TK+459)~14000	(TJ+1013)~14000	500~14000
								35°	Indoor	(TK+538)~16000	(TJ+855)~16000	/
									Semi-outdoor/Outdoor	(TK+538)~14000	(TJ+855)~14000	/
27.3°	Indoor	(TK+416)~16000	(TJ+1095)~16000	500~16000								
	Semi-outdoor/Outdoor	(TK+416)~14000	(TJ+1095)~14000	500~14000								